

ON-WALL SPEAKERS

Model **EMS**
SPEAKER STANDS



EMP
Tek

USER & INSTALLATION MANUAL

Kit Contents

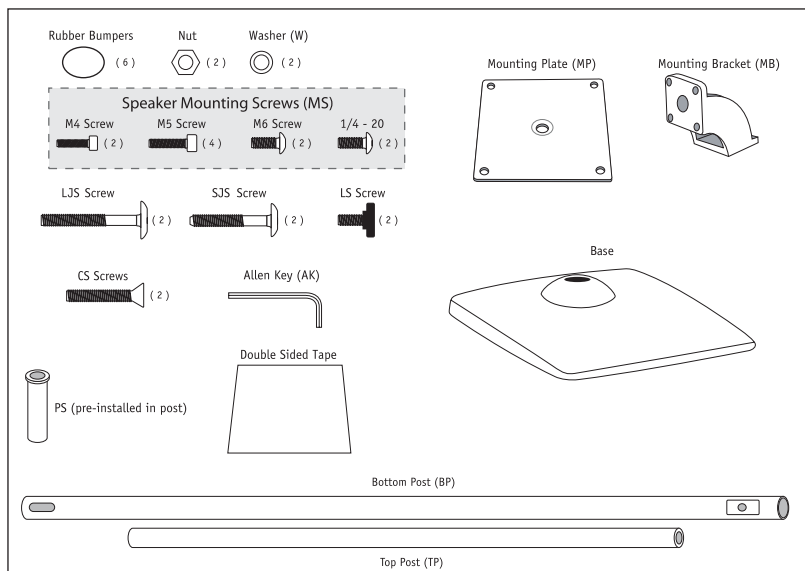

Instructions

- Step 1.** Attach the Bottom Post (BP) to the Base with the Long Joining Screw (LJS) and Allen Key (AK) supplied. NOTE: Please make sure that the wire management hole faces to the back of the base. (see diagram 1)
- Step 2.** Attach the Rubber Bumpers (RB) to the underside of the base. (see diagram 1)
- Step 3.** Insert the Top Post (TP) into the Bottom Post (BP). Make sure that the Wire Management Hole is to the top. (see diagram 2)
- Step 4.** Install the Locking Screw (LS) into the threaded hole in the top of the Bottom Post (BP), and tighten. (see diagram 2)
- Step 5.** Attach the Mounting Bracket (MB) to the Top Post (TP) using the Short Joining Screws (SJS) and Allen Key (AK), make sure the back of the mounting bracket faces the wire management hole. (see diagram 3).
OPTIONAL: Attach the Mounting Plate (MP) to the Top Post (TP) using the Counter Sink Screws (CS) and Allen Key (AK). Use the Double-Sided Tape to prevent the speaker from sliding by adhering the tape in between the mounting plate and the speaker. Using the tape is optional as it may not be removable later.
- Step 6.** Attach the speakers to the Mounting Bracket (MB) using the appropriate Mounting Screw (MS) and Washer (W) for your speaker. Tighten firmly, using the Allen key (AK) supplied. (see diagram 3)
- Step 7.** Adjust the stand height by loosening the Locking Screw (LS), adjusting the height of the speaker to the desired height and then re-tightening the Locking Screw (LS) fully. Feed the speaker wire through the post and connect to the system. (see diagram 4)
- Step 8.** Repeat steps 1 through 7 for other stand.

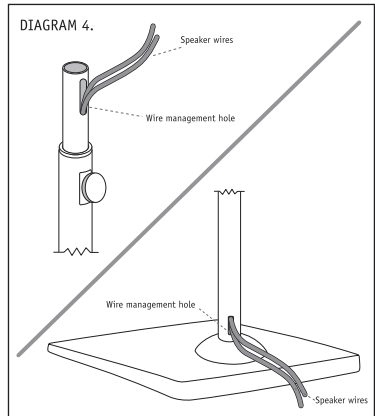
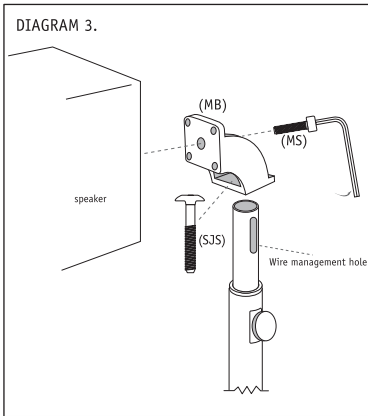
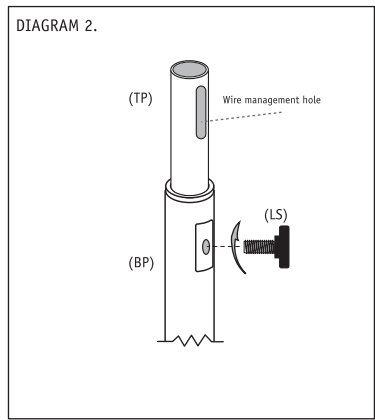
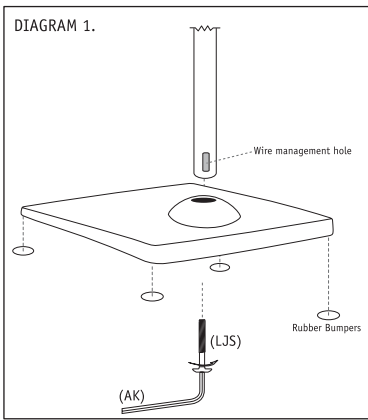

Warranty

Your EMS Speaker Stands are covered by a limited warranty against defects in materials and workmanship for a period of 1 year from the original date of purchase. This warranty is provided by the authorized EMP Tek dealer where the speaker was purchased. Warranty repair will be performed only when your purchase receipt is presented as proof of ownership and date of purchase. Defective parts will be repaired or replaced without charge by your dealer's store or the location designated by your dealer authorized to service EMP Tek products. Charges for unauthorized service and transportation cost are not reimbursable under this warranty. This warranty becomes void if the product has been damaged by alteration, misuse or neglect. The warrantor assumes no liability for property damage or any other incidental or consequential damage whatsoever which may result from the failure of this product. Any and all warranties of merchantability and fitness implied by law are limited to the duration of this express warranty. Some states do not allow limitations on how long an implied warranty lasts, so the above limitations may not apply to you. Some states do not allow the exclusion or limitation of incidental or consequential damages, so the above limitation or exclusion may not apply to you.



382 Marshall Way, Layton, Utah • USA • 84041
Toll Free: (800) 543-2205 • Fax: (801) 543-3300
www.emptek.net